

NOTE: ALL MEASUREMENTS MUST BE ACCURATE, USE TWO PEOPLE ON LARGE WINDOWS.

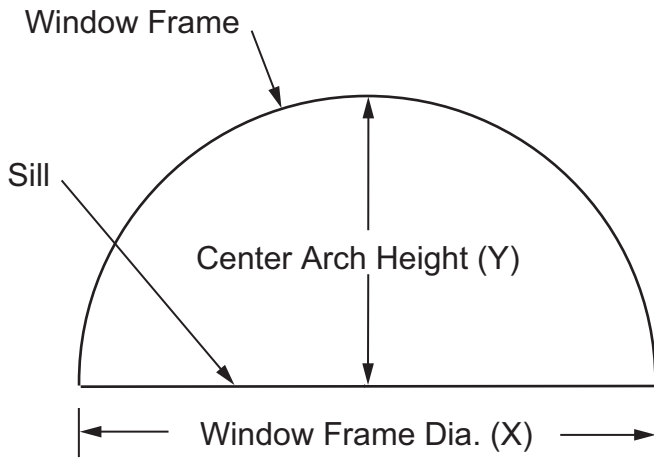

**STEP 1.**

Measure diameter (X). Measure radius (Y). Ideally,  $1/2 (X) = (Y)$ . Height (Y) must be within  $\pm 2"$  of  $1/2$  diameter (X).

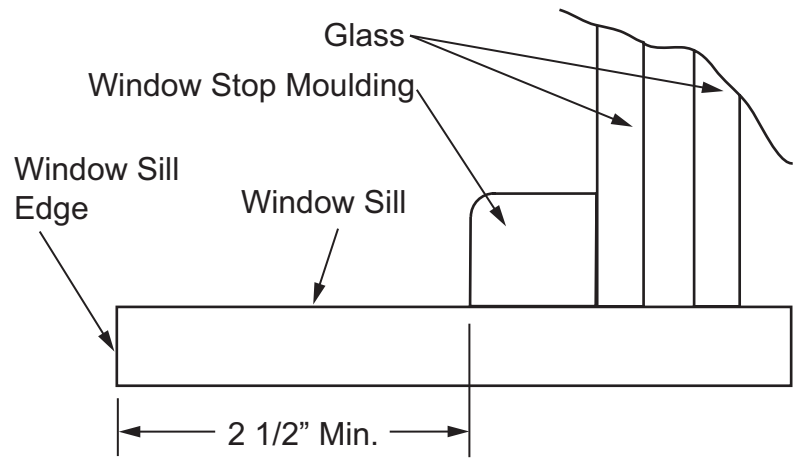

**STEP 2.**

Measure distance from the edge of the sill to the window stop moulding. **2 1/2" required.** (If less order sill extension)

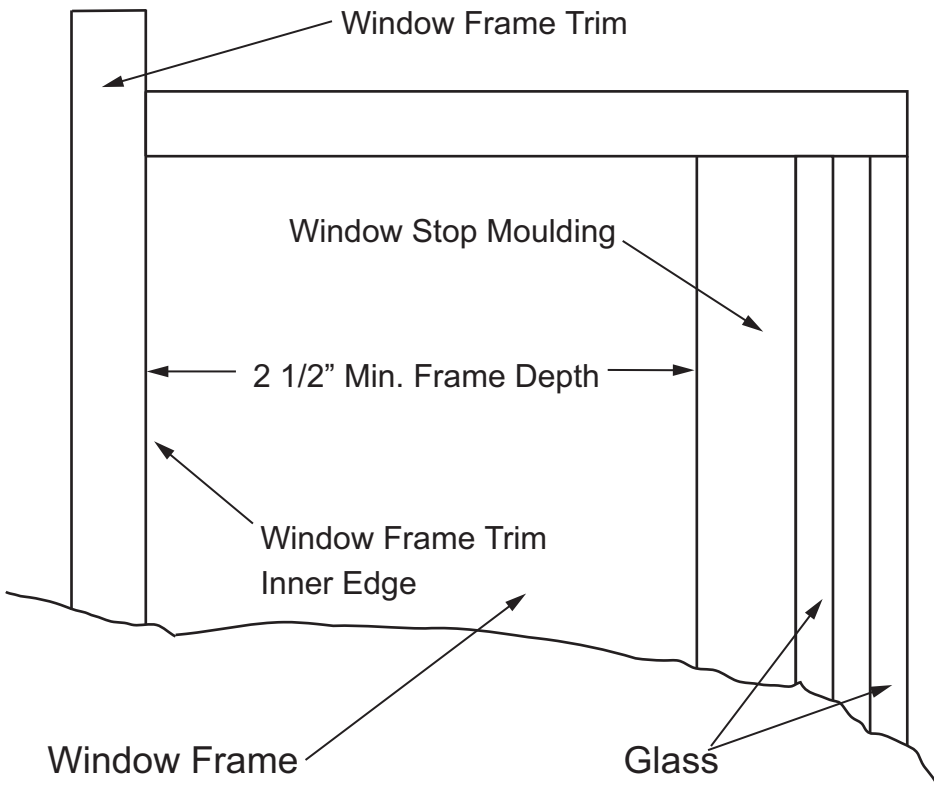

**STEP 3.**

Measure distance from inner edge of window frame trim to the window stop moulding. **Min. 2 1/2" required.** (If less, track frame will protrude into room.)

**STEP 4.**

Once it is determined window is a candidate for the ADJUST-A-VIEW® system select shade option from Retail Price sheet.

Revised 23-JAN-12

