

NOTE: ALL MEASUREMENTS MUST BE ACCURATE, USE TWO PEOPLE ON LARGE WINDOWS.

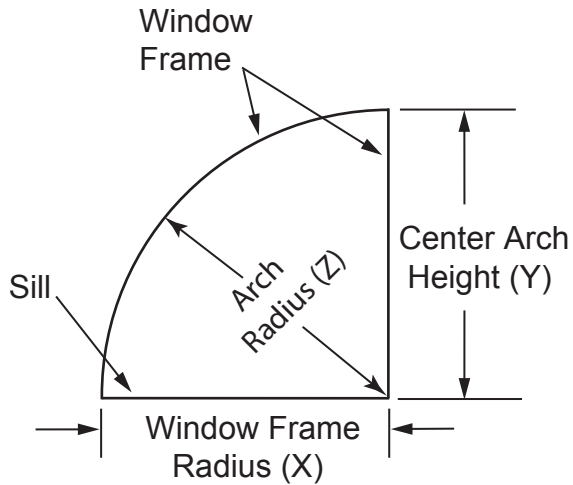

STEP 1.

Measure window frame radius (X). Measure arch height (Y), it must be within +/- 1" of radius (X). Measure arch radius (Z). Enter all three dimensions on the order form.

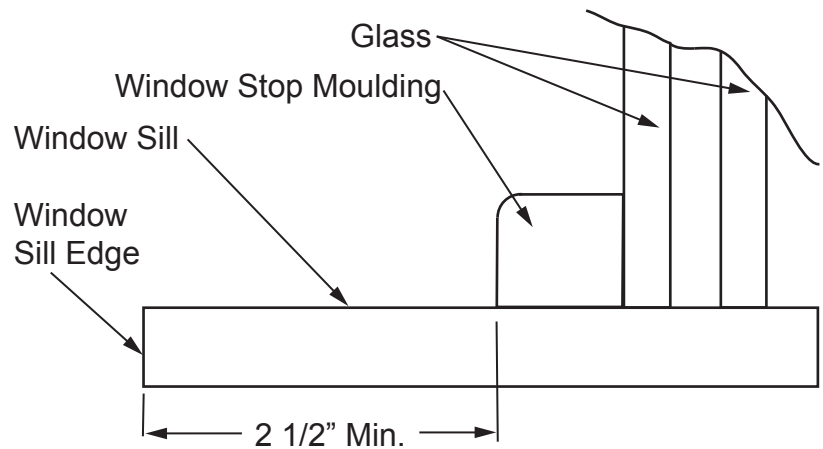

STEP 2.

Measure distance from the edge of the sill to the window stop moulding. **Min. 2 1/2" required.** (If less order sill extension.)

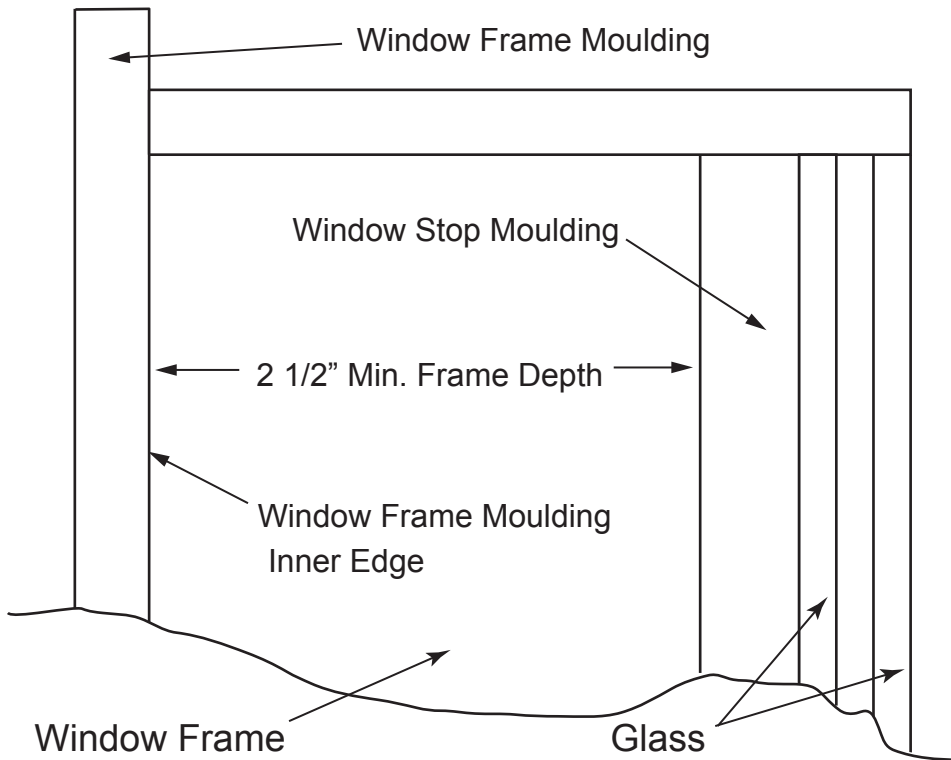

STEP 3.

Measure distance from inner edge of window frame moulding to the window stop moulding. **Min. 2 1/2" required.** (If less, track frame will protrude into room. Up to 1/2" protrusion into room is allowable.)

STEP 4.

Once it is determined window is a candidate for the ADJUST-A-VIEW® system select shade option from Retail Price sheet.

Revised 06-NOV-06

